

## RLM122-BHP • RLM126-BHP

### DIFFUSE REFLECTIVE SENSOR

- ▷ integrated amplifier
- ▷ compact design
- ▷ stainless steel housing
- ▷ long range



	RLM122-BHP	RLM126-BHP
Light type	infrared	
Functional principle	pulsed	
Max. frequency response	500Hz	
Function indicator	LED red	
Switching function	light-on	
Operating voltage	10...30VDC reversed polarity protection	
Current Consumption	30mA	
Output current	PNP 100mA short circuit proof	
Nominal switching distance*	10mm...180mm	
Hysteresis	<15%	
Response time	<1,5ms	
Temperature range	-10°C to +55°C	
Housing material	stainless steel	
Weight	35g	20g
Protection class	IP65	
Supply connection	2m PUR-cable 3 x 0,09	Connector M8, 3poles
Adjustment indicator	LED blinking 2Hz	LED blinking 2Hz
Short circuit indication	LED blinking 8Hz	LED blinking 8Hz

\*on white photopaper 50mm x 50mm

**DIMENSIONS**

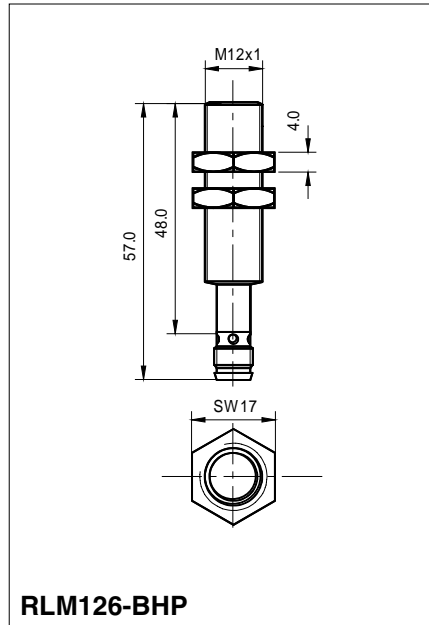
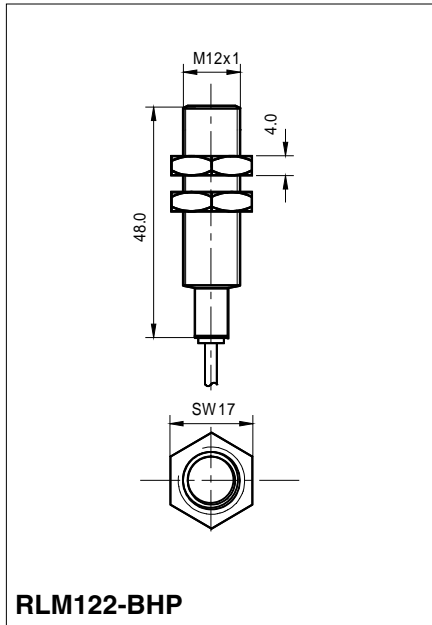

**CONNECTION-DIAGRAM**

**SUPPLY AND OUTPUT**

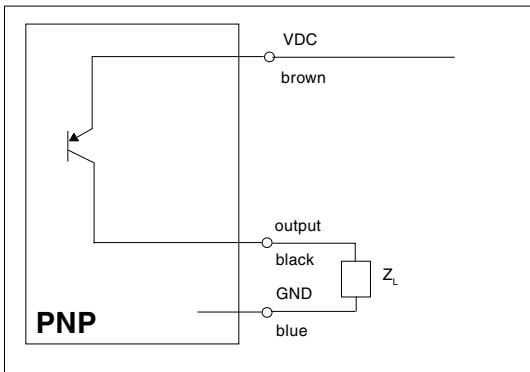

**RLM122-BHP**

- brown + VDC
- blue - GND
- black signal output

**RLM126-BHP**

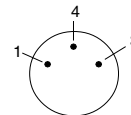

- 1 (brown) VDC
- 4 (black) output
- 3 (blue) GND

(supply cable to be ordered separately)

**ORDER EXAMPLE**

<b>RLM122-BHP:</b>	pulsed	light-on	PNP-output
<b>RLM126-BHP:</b>	pulsed	light-on	PNP-output