

DL40L • DLM50L • DLV60L

MINI THROUGH BEAM SENSOR
with separate amplifier

- ◉ small housing diameter
- ◉ high excess gain
- ◉ highly flexible cable
- ◉ small light beam diameter
- ◉ robust design



<ul style="list-style-type: none"> • Ø 4 mm x 11 mm • Stainless steel • f. gluing or clamping fixture 	<p>DL40L</p>  <p>Actual size</p>
<ul style="list-style-type: none"> • M5 x 0,5 mm x 11 mm • Nickel-plated brass • f. screw-in fixture 	<p>DLM50L</p>  <p>Actual size</p>
<ul style="list-style-type: none"> • 6 mm x 6 mm x 12 mm • Nickel-plated brass • f. screw-in fixture 	<p>DLV60L</p>  <p>Actual size</p>

GENERAL TECHNICAL DATA

light type	Red 660nm or Infrared 880nm
connection type	PUR-cable with connector
temperature range	-10°C to +55°C
protection class	IP 65

SMALLEST OBJECT and SENSING DISTANCE

sensing distance	2000 mm
smallest object (Ø copper wire)*	0,3 mm

*copper wire of infinite length

DIMENSIONS

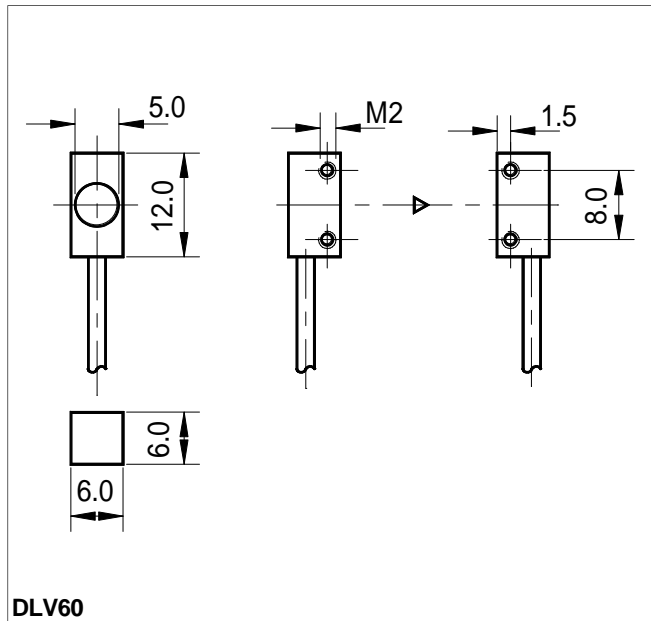
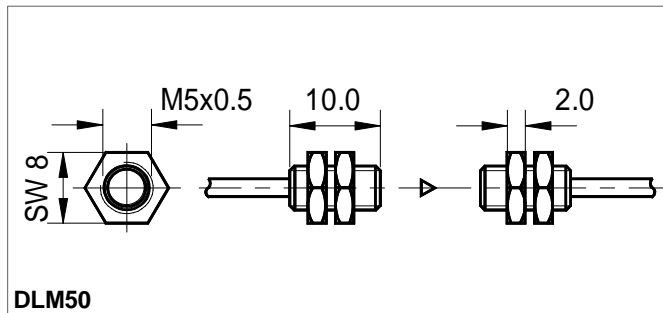
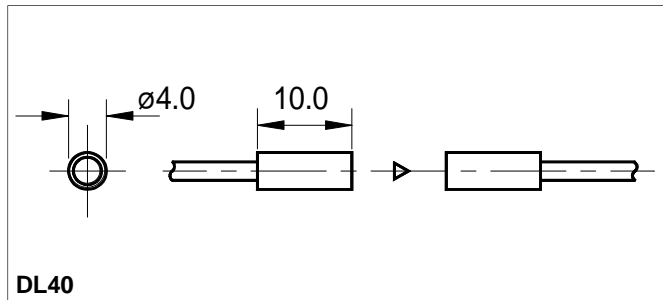

PART DESIGNATION

DL40 **L** - - :

light type

- R: Red light
- (blank): Infrared light

jacket material

- P: PUR-cable black Ø1,8mm
- F: highly flexible PUR-cable red Ø1,1mm

cable length (specifications in [m])

- standard length 1m
- special cable length

connector

- 0: M8 - connector 3 pin, female
- 1: 719 - connector
(see page *Options and Accessories*)

ORDER EXAMPLE:

DL40RL-P-0:1m = DL40L Red light - PUR-cable black - M8, 3 pin female: (cable length 1m x 2)

Please remember, for correct operation, a separate amplifier is required.